

Italian Style



ASSA ABLOY

ASSA ABLOY, the global leader
in door opening solutions



Lucchetti a baionetta in ottone

Bayonet brass padlocks

Scatola o Blister

Box or Blister

Caratteristiche tecniche:

- **Chiave**
2 per lucchetto
Estrazione chiave a lucchetto chiuso
- **Gancio:**
Acciaio cementato e cromato
- **Catenaccio:**
A sfera in acciaio
- **Corpo:**
Ottone massiccio, spigoli arrotondati,
protetto con vernice trasparente
- **Meccanismo:**
Contropistoncini a fungo antigrimaldello
Pistoncini in ottone
Molle in acciaio inox
Richiamo automatico della chiave
nella posizione di estrazione
- **A richiesta:**
Esecuzioni speciali:
KA - KAR - KAS - MK -GMK - CC

Features:

- **Key**
2 each padlock
Key withdrawal with shackle closed
- **Shackle:**
Chrome plated case-hardened steel
- **Locking:**
Sphere in steel
- **Body:**
Solid brass with rounded corners protected
by varnish and glazed
- **Mechanism:**
Antipick mushroom drivers
Brass pins
Inox springs
Automatic return of
key to extraction position
- **On request:**
Special arrangements:
KA - KAR - KAS - MK -GMK - CC



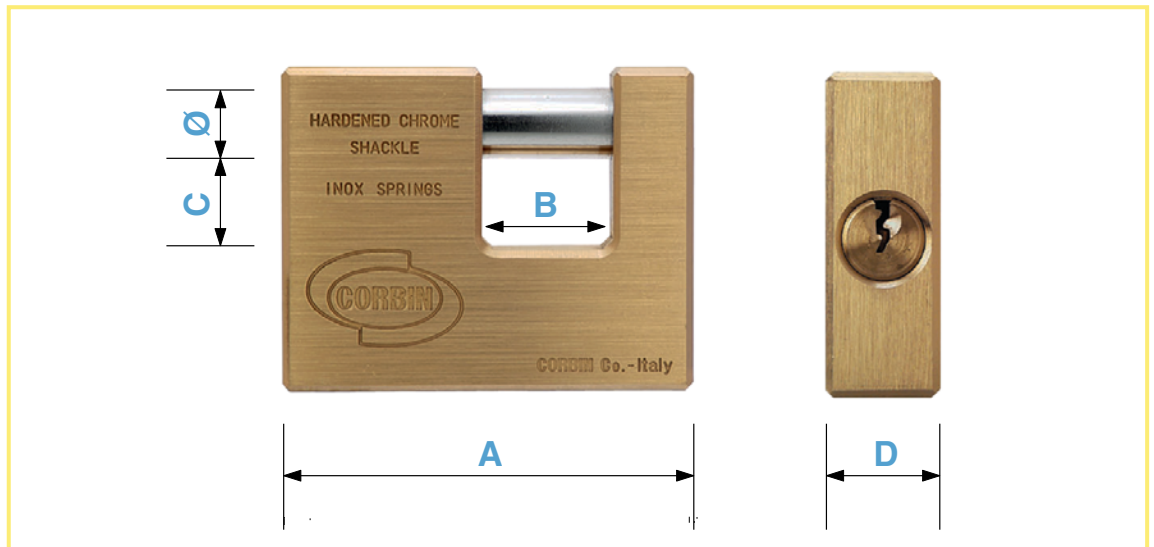

Scatola
Box



Codice / Code	A	Ø	B mm	C	D				
PL301 50 00	50	6	17	11	15	4	PK100 57 01	190	6
PL301 60 00	60	10	18	10	17	5	PK100 58 01	330	6
PL301 70 00	70	12	22	15	20	5	PK100 59 01	530	6
PL301 90 00	90	12	36	18	20	5	PK100 59 01	770	6

Blister





PL301 51 00	50	6	17	11	15	4	PK100 57 01	190	12
PL301 61 00	60	10	18	10	17	5	PK100 58 01	330	12
PL301 71 00	70	12	22	15	20	5	PK100 59 01	530	12
PL301 91 00	90	12	36	18	20	5	PK100 59 01	770	12

Chiavi grezze (Ottone nichelato)

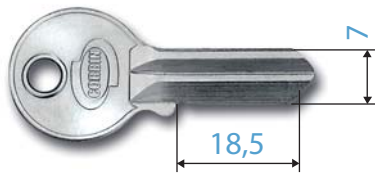
Key blanks (Nickel plated brass)



		
50 mm	PK100 57 01	50

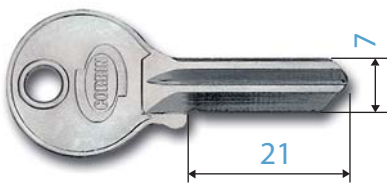

		
60 mm	PK100 58 01	50

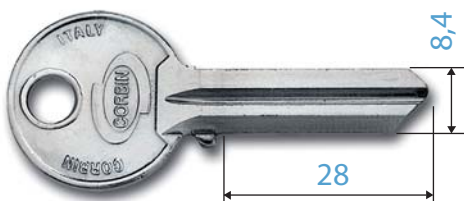

		
70 - 90 mm	PK100 59 01	100

Impianti di cifratura speciale

Special arrangements

KA	Impianto a chiave uguale (cifratura a ns. scelta) <i>Keyed alike installation (keyed to our choice)</i>	GMK	Impianto a chiave maestra generale <i>Grand master key installation</i>
KAR	Impianto chiave uguale (cifratura registrata) <i>Keyed alike installation (Coded keyed)</i>		
KAS	Impianto chiave uguale (cifratura uguale al campione) <i>Keyed alike installation (keyed as per sample)</i>		

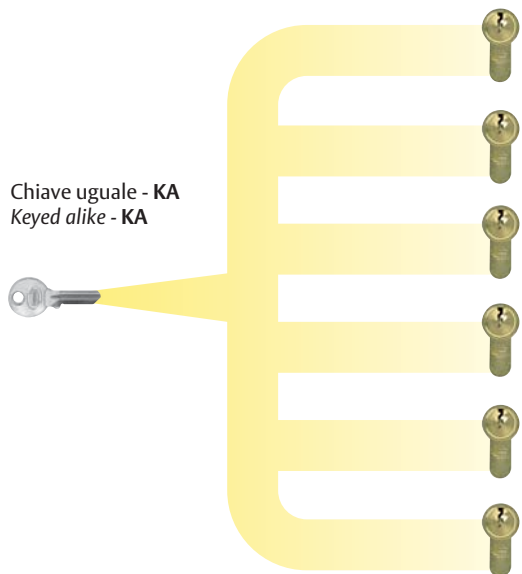

Tutte le serrature (cilindri o lucchetti) sono aperte con la stessa chiave
All locks (cylinders or padlocks) opened by the same key

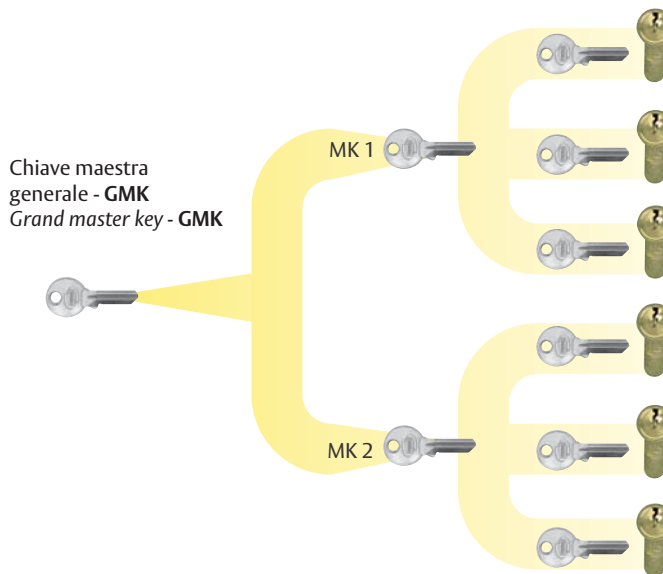

Ogni serratura (cilindri o lucchetti) è aperta dalla propria chiave individuale, dalla Chiave Maestra appartenente al gruppo, e dalla Chiave Maestra Generale
Each locks (cylinders or padlocks) is opened by its own key, Master Key, and the Grand Master Key

MK	Impianto a chiave Maestra <i>Master Key installation</i>	CC	Impianto a Cilindro Centrale <i>Central locking installation</i>
-----------	---	-----------	---

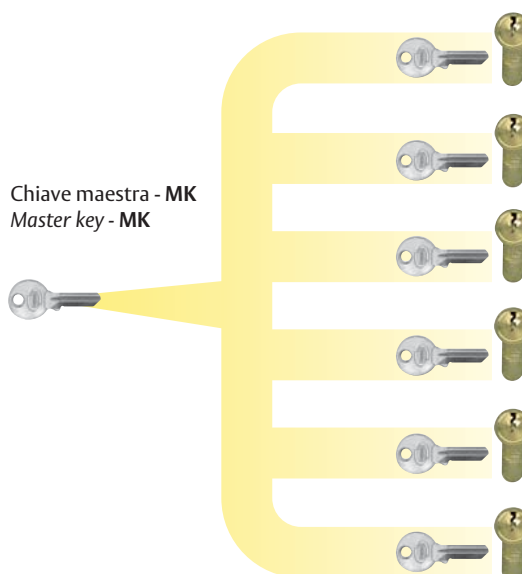

Ogni serratura (cilindro o lucchetto) è aperta dalla propria chiave individuale e dalla chiave Maestra
Each lock (cylinder or padlock) is opened by its own individual key, and the Master Key

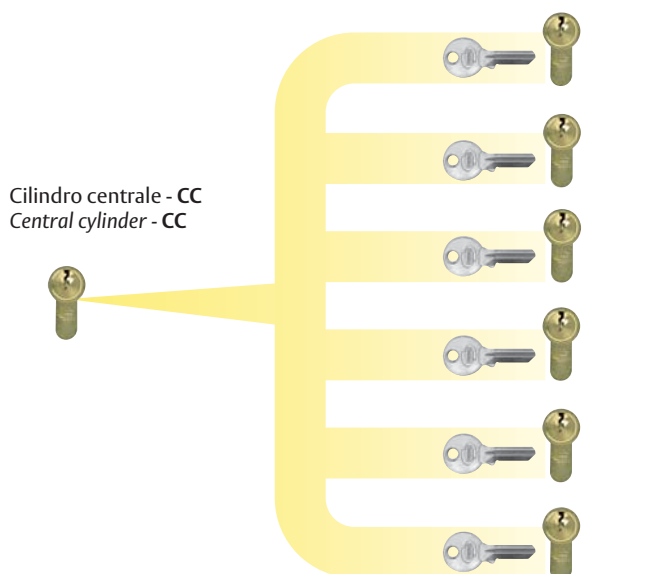

Ogni chiave apre la serratura (cilindro o lucchetto) centrale e la propria serratura (cilindro o lucchetto) individuale
Each key opens the central lock (cylinder or padlock) and open its own individual lock (cylinder or padlock)



ASSA ABLOY Italia S.p.A.
Via Modena 68 - 40017 San Giovanni in Persiceto (BO) Italy
Tel. +39 051 6812411 - Fax +39 051 827486
info@assaabloy.it - www.assaabloy.it

ASSA ABLOY is the global leader in door opening solutions, dedicated to satisfying end-user needs for security, safety and convenience.

www.assaabloy.com

